

**Voltage Range 50 to 600 V**  
**Current 10.0 Ampere**

**Features**

- Fast switching for high efficiency
- Low forward voltage drop
- High current capability
- Low reverse leakage current
- High surge current capability

**Mechanical Data**

- Case: Molded plastic ITO-220AB
- Epoxy: UL 94V-0 rate flame retardant
- Terminals: Solderable per MIL-STD-202 method 208
- Polarity: Color band denotes cathode
- Mounting position: Any
- Weight: 1.73 gram

**Dimensions in inches and (millimeters)**

**ITO-220AB**

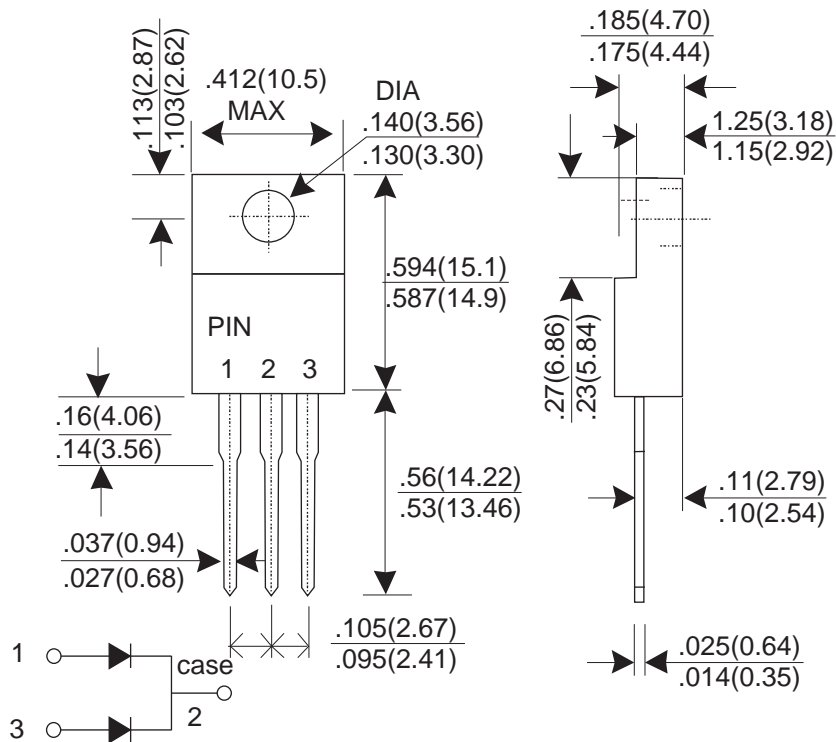

Dimensions in inches and (millimeters)

## MAXIMUM RATINGS AND ELECTRICAL CHARACTERISTICS

Rating at 25°C ambient temperature unless otherwise specified.  
 Single phase, half wave, 60Hz, resistive or inductive load.  
 For capacitive load, derate current by 20%.

PARAMTER	SYMBOL	TUF 10C01CF	TUF 10C02CF	TUF 10C03CF	TUF 10C04CF	TUF 10C05CF	UNIT
Maximum Recurrent Peak Reverse Voltage	VRRM	50	100	200	400	600	V
Maximum RMS Voltage	VRMS	35	70	140	280	420	V
Maximum DC Blocking Voltage	VDC	50	100	200	400	600	V
Maximum Average Forward Rectified Current Tc=100°C	IF(AV)	10.0					A
Peak Forward Surge Current, 8.3ms single Half sine-wave superimposed on rated load (JEDEC method)	IFSM	125					A
Maximum Instantaneous Forward Voltage @ 5.0 A	VF	1.0		1.3	1.7	V	
Maximum DC Reverse Current @TJ=25°C At Rated DC Blocking Voltage @TJ=125°C	IR	5.0 250					uA uA
Maximum Reverse Recovery Time (Note 1)	Trr	50				75	nS
Typical junction Capacitance (Note 2)	CJ	65					pF
Typical Thermal Resistance (Note 3)	RθJC	2.2					°CW
Operating Junction and Storage Temperature Range	TJ, TSTG	-55 to +150					°C

NOTES : (1) Reverse recovery test conditions IF = 0.5A, IR = 1.0A, Irr = 0.25A.  
 (2) Measured at 1.0 MHz and applied reverse voltage of 4.0 Volts DC.  
 (3) Thermal Resistance junction to case.

RATING AND CHARACTERISTIC CURVES

FIG.1 - FORWARD CURRENT DERATING CURVE

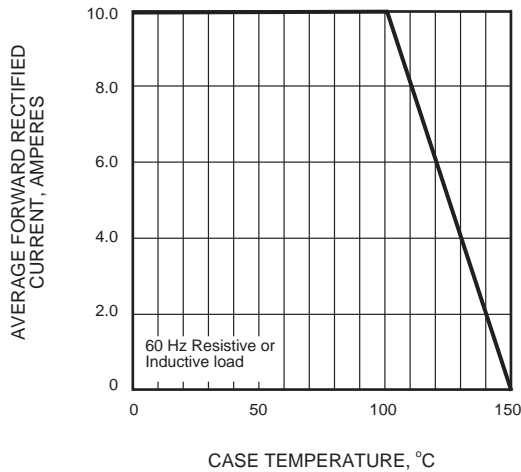

FIG.2 - MAXIMUM NON-REPETITIVE PEAK FORWARD SURGE CURRENT

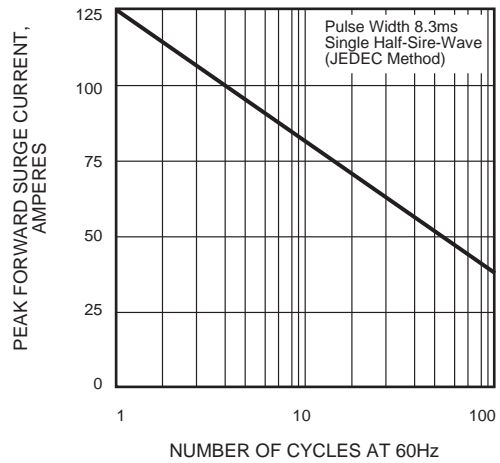

FIG.3 - TYPICAL INSTANTANEOUS FORWARD CHARACTERISTICS

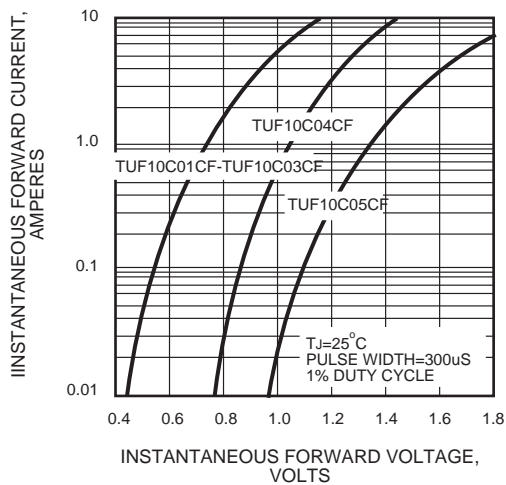

FIG.4 - TYPICAL REVERSE CHARACTERISTICS

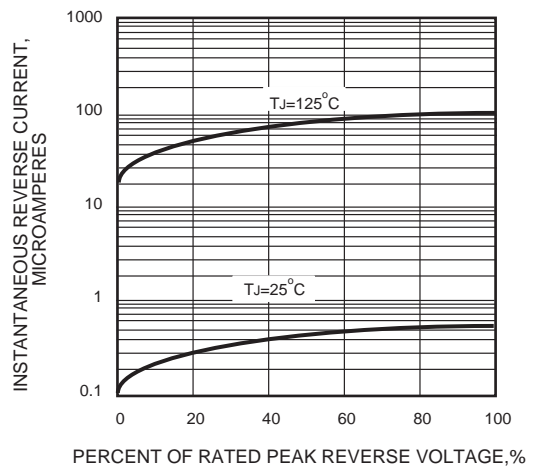

FIG.5 - TYPICAL JUNCTION CAPACITANCE

